



**PERFORMANCE DATA SHEET
NEMA PREMIUM NR CAN NEMA 12 - 12**

Catalogue #: MQP-58

HP	kW	Voltage	S.F. @ 60Hz	EFF.	P.F.	Frame	Design	L.R. Amps
40	29,84	230/460	1,25	94,1%	0,78	364T	B	290

60 Hz							Code	F.L. RPM
208	230	416	460	480	575	600		
/	102	/	51,00	/	/		G	1188

50 Hz								
FLA			S.F. @ 50Hz	Efficiency	Power Factor	Code	F.L. RPM	
190	380	415						
122,0	61		1,00	92,4%	0,800	D	985	

Wgt. Lbs	PH	Duty	Insul. Class	Amb.	Elevation	Temp. Rise° C
697	3	Cont.	F	40°C	1000M (3,300 Ft)	60

% Efficiency		% Power Factor		Torque		Winding Resist. Ω	Safe Cold Start (Secs)
Full Load:	94,1%	Full Load:	0,78	Full Load Ft/Lbs	176,8		
3/4 Load:	94,1%	3/4 Load:	0,75	Locked Rotor %	155		
1/2 Load:	93,6%	1/2 Load:	0,66	Break Down %	250	0,17	20

Rotor Inertia Wk2 Lb-Ft2	Max Load Inertia Wk2 Lb-Ft2	Shaft Material	Frame Material	DE Bracket Type	ODE Bracket Type	Enclosure	NEMA Rating	Lead Wire Size
14,24	686,6	1045	Cast Iron	Cast Iron	Cast Iron	TEFC	IP55	8AWG

Ball Bearings		Grease	Mount Type	Orientation	Paint	Sound Pressure @ 3FT	Sound Power
DE	ODE						
6313	6313	Mobil PolyrexEm	Rigid	Horizontal	RAL6022	75	86

Inverter Duty, Motor meets MG1 parts 31.4.4.2	VFD SF	Constant Torque Range	Variable Torque Range	Constant HP RPM
	1,00	10:1	20:1	1800

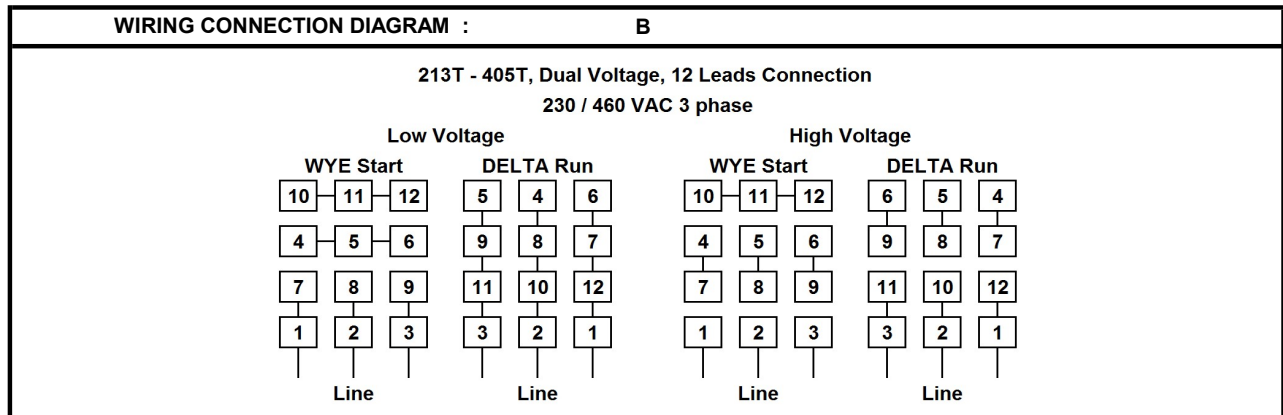

Date: 2023-12-13
 Customer: _____
 Contact: _____
 Submittee: J.C. Lavallée

Catalogue #: **MQP-58**

NEMA PREMIUM NR CAN NEMA 12 - 12										
HP	VAC	RPM	Enclosure	Frame	Frequency	Design	Poles	LR Code Letter	Insulation Class	Temp. Rise °C
40	460	1188	TEFC	364T	60 Hz	B	6	G	F	60
	0Hz	6Hz	15Hz	30Hz	45Hz	60 Hz	75Hz	90Hz	105Hz	120Hz
Amps	51	51	51	51	51	51	51	51	51	51
RPM	0	118,8	297	594	891	1188	1485	1782	2079	2376
Torq ft.lb	141,47	141,47	176,84	176,84	176,84	176,84	141,47	117,89	101,05	88,42
Peak Tq ft.lb	198,94	397,88	397,88	397,88	397,88	397,88	318,30	265,25	227,36	198,94
HP	0	3,2	10,0	20,0	30,0	40,0	40,0	40,0	40,0	40,0
	Locked Rotor	Pull-Up	Breakdown	Rated Load	Idle	Duty	S. F.	Ambient	Elevation	dBa @ 1M
Speed (RPM)	0,0	504	960	1188	1200	Continuous	1,25	40°C	3,300 ft	75
Current (Amps)	290,0	246,5	172,6	51,0	19,4	VFD Rating: Meets MG1 parts 31.4.4.2				
Torque (ft-lbs)	274,1	205,6	442,1	176,8	0,0	C.T.	10:1	V.T.	20:1	VFD SF 1.00

Motor Speed Data

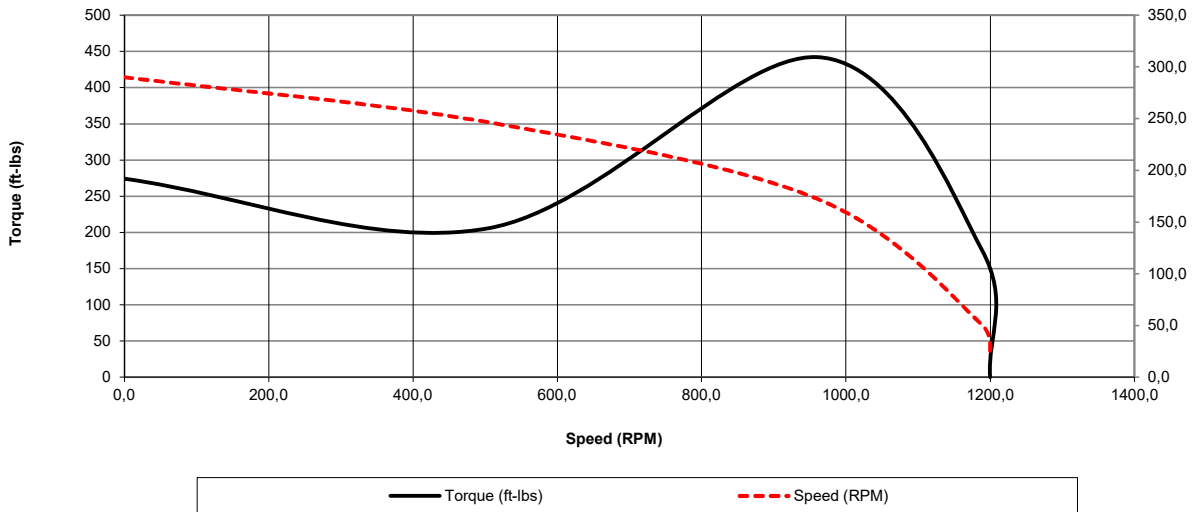

Motor Torque Capability vs RPM

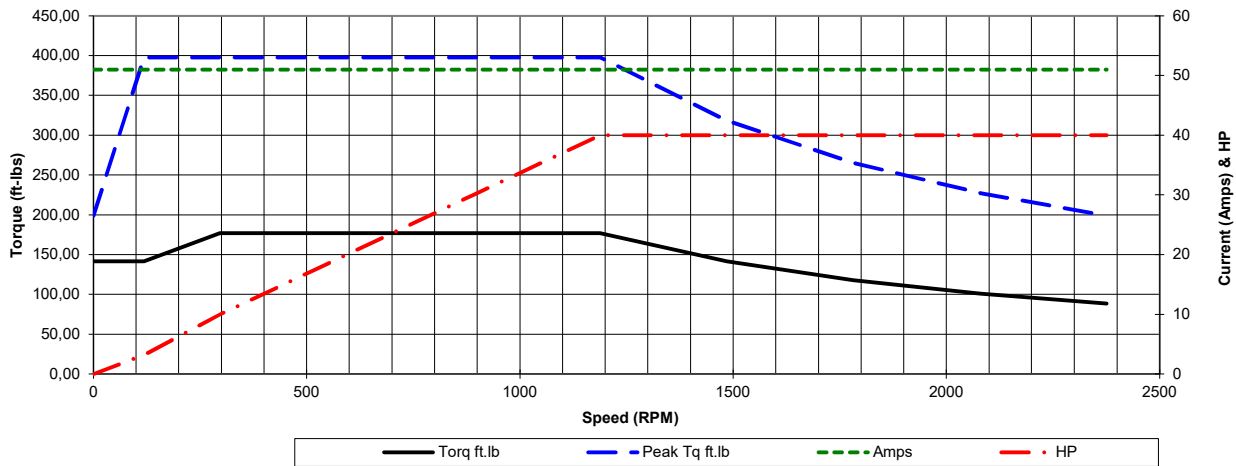



Date: 2023-12-13
 Customer: _____
 Contact: _____
 Submittee: J.C. Lavallée

Catalogue #: **MQP-58**

NEMA PREMIUM NR CAN NEMA 12 - 12										
HP	VAC	RPM	Enclosure	Frame	Frequency	Design	Poles	LR Code Letter	Insulation Class	Temp. Rise °C
40	460	1188	TEFC	364T	60 Hz	B	6	G	F	60
Load %	0%	25%	50%	75%	100%	125%	150%			
Amps	19,38	21,78	30,19	39,83	51,00	65,46	79,66			
Torq ft/lbs	0	43,88	87,97	132,29	176,84	221,60	266,60			
RPM	0	1197	1194	1191	1188	1185	1182			
Eff	0	90,52	93,60	94,10	94,10	92,62	92,26			
PF	0	47,5	66	75	78	77,22	76,44			
	Locked Rotor	Pull-Up	Breakdown	Rated Load	Idle	Duty	S. F.	Ambient	Elevation	dBa @ 1M
Speed (RPM)	0	504	960	1188	1200	Continuous	1,25	40°C	3,300 ft	75
Current (Amps)	290	246,5	172,6	51	19,38	VFD Rating: Meets MG1 parts 31.4.4.2				
Torque (ft-lbs)	274,09	205,57	442,09	176,84	0,0	C.T.	10:1	V.T.	20:1	VFD SF 1.00

